



BOBRICK
Technical Data

**MIRROR WITH
STAINLESS STEEL
ANGLE FRAME
AND SHELF**

**B-292
SERIES**



Designer's Notes:

1. Special-order sizes available on request.
2. Maximum size one-piece angle-frame mirror, 96" x 72" (244 x 183cm); minimum size, 12" x 12" (30 x 30cm).
3. All Bobrick framed mirror/shelf models are manufactured to overall width and height dimensions of mirror, not including shelf. EXAMPLE: For "2S" Tab Design B-292 2436 (61 x 95cm) mirror will be furnished 24" x 37-1/4" (61 x 94cm) outside-of-frame to outside-of-frame including shelf.
4. To specify special sizes use Series Number followed by width x height in inches. EXAMPLE: B-292 2024 20" x 24" (51 x 61cm).
5. Bobrick framed mirror/shelf models are manufactured to a tolerance $\pm 1/8"$ (3.2mm).
6. For sufficient space to lift mirror onto wall hanger(s), provide 1" (25mm) minimum clearance above top of mirror frame.
7. 1/2" (12.7mm) clearance on each side.

**Snap Locking Design
(Rear View)**

Figure: 1

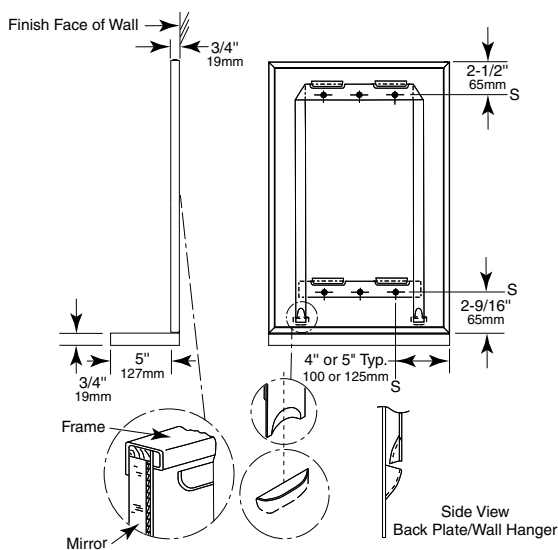

STANDARD B-292 SERIES MIRRORS

MODEL NO.	OVERALL SIZE	
	W	H
B-292 1836	18" (46cm)	36" (91cm)

**"2S" Tab Design
(Rear View)**

- for all other mirrors up to a width of 36"

Figure: 2

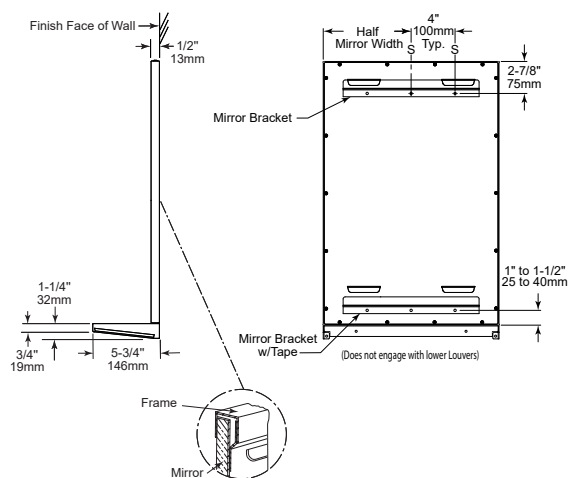

Note: Mirrors greater than 36" in width will have multiple hanger bracket pockets with a typical 8" off each edge.

MATERIALS:

Frame — 18-8, Type-304, heavy-gauge stainless steel, 3/4" x 3/4" (19 x 19mm) angle with satin finish. One-piece, roll-formed construction forms continuous integral stiffener on all sides. Bevel design on front of angle holds frame tightly against mirror. Corners of mirror frame are heliarc welded, ground, and polished smooth. Galvanized steel back is fastened to frame with concealed screws and equipped with integral horizontal hanging brackets near the top for hanging the mirror and near the bottom to prevent the mirror from pulling away from the wall. Locking devices secure mirror to concealed wall hanger.

© 2021 by Bobrick Washroom Equipment, Inc.

Shelf — 18-8, Type-304, 18-gauge (1.2mm) stainless steel with satin finish, 3/4" (19mm) return edge on front. Front and side return edges hemmed for additional strength and safety. Front corners of shelf are welded, ground, and polished smooth. Shelf is welded to mirror frame. No exposed rivet-heads, screws, or fasteners of any type on frame or shelf.

Mirror — No. 1 quality, 1/4" (6mm) select float glass (standard glass): selected for silvering, electrolytically copper-plated by the galvanic process, and guaranteed for 15 years against silver spoilage. All edges protected by plastic filler strips; back is protected by full-size, shock-absorbing, water-resistant, nonabrasive, 3/16" (5mm) thick polyethylene padding.

Concealed Wall Hanger — For snap locking design: Heavy gauge steel construction. Incorporates upper and lower members, which engage backplate louvers to keep mirror against the wall. For "2S"-Tab design: Incorporates upper bracket engaging in upper louver and double sided tape below the bottom louver securing mirror to concealed wall hanger.

INSTALLATION:

Mount wall hanger on wall with screws (not furnished) at points indicated by an S. For plaster or dry wall construction, provide backing to comply with local building codes, then secure wall hanger with screws (not furnished). When providing a concealed backing, allow backing to cover range of mounting hole locations shown on drawing. For other wall surfaces, provide fiber plugs or expansion shields for use with screws (not furnished), or provide 1/8" (3mm) toggle bolts or expansion bolts.

Snap Locking Design: Hang mirror on wall hanger with all four backplate louvers engaged behind horizontal wall hanger members. To do this, mirror must be centered in front of the wall hanger horizontally, pressed flat against the wall approximately 1" (25mm) above final position and then lowered into final position.

"2S" Tab Design: Comprises of two brackets, while the bottom one is furnished with double side tape. Bottom hanger bracket's mounting holes must be 1" - 1 1/2" above mirror's bottom edge. Note: Bottom hanger bracket is not supposed to engage with louvers of mirror's backplate. Hang mirror on wall top hanger bracket with the top two louvers engaged behind top wall hanger bracket. To do this, mirror must be centered in front of the wall hanger horizontally, pressed only at the top against the wall approx. 1" (25mm) above final position and then lowered into final position. When lowering, pull mirror's bottom edge off the wall by preventing bottom bracket from engaging. Once lowered, mirror must be pressed against wall to engage with double sided tape of lower wall hanger bracket.

Snap Locking Design — Locking devices automatically secure mirror to concealed wall hanger when it is lowered into final position (see figure 3). Locking devices may be unlocked by inserting two flat blade screwdrivers behind each side of mirror near the bottom or under the bottom of the mirror and pulling mirror bottom forward and then up.

"2S" Tab Design — Double-sided tape secures mirror to concealed wall hanger by pressing mirror against double sided tape of lower hanger once it is lowered into final position (see figure 4).

**Snap Locking Design
(Front View)**

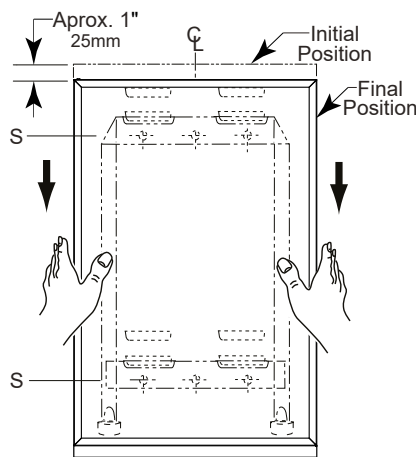

Figure: 3

**"2S" Tab Design - up to 36" Width
(Front View)**

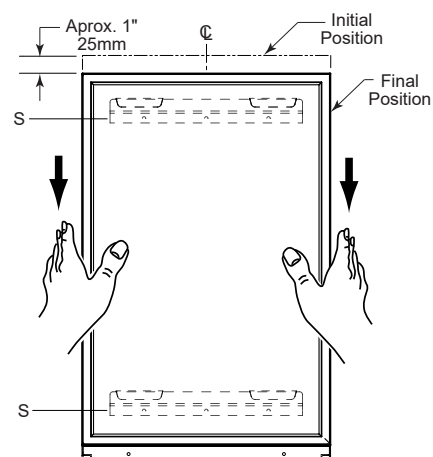

Figure: 4

SPECIFICATION:

Mirror shall have a one-piece, Type-304 stainless steel angle frame, 3/4" x 3/4" (19 x 19mm) with continuous integral stiff-ener on all sides and beveled front to hold frame tightly against mirror; corners shall be heliarc welded, ground, and polished smooth; all exposed surfaces shall have satin finish. Shelf shall be Type-304, 18-gauge (0.8mm) stainless steel with satin finish. Shelf shall have a 3/4" (19mm) return edge on front. Front and side return edges hemmed and corners welded, ground, and polished smooth. Shelf shall be welded to mirror frame. No rivet-heads, screws, or fasteners of any type shall be exposed on frame or shelf. Select float glass mirror shall be guaranteed for 15 years against silver spoilage. All edges shall be protected by plastic filler strips and the back shall be protected by full-size, shock-absorbing, water-resistant, nonabrasive, 3/16" (5mm) thick polyethylene padding. Galvanized steel back shall have integral horizontal hanging brackets located at top and bottom for mounting on concealed wall hanger and to prevent the bottom of the mirror from pulling away from the wall. Locking devices secure mirror to concealed wall hanger. Mirror shall be removable from wall hanger for reglazing mirror.

© 2021 by Bobrick Washroom Equipment, Inc.